

**INSTALLATION INSTRUCTIONS FOR THE BYRNE INTERPORT®**

Tools: Electric Drill, 1/8" (.125 Dia.) & 3/8" (.375 Dia) drill bit, saber saw, rasp.

1. Install data jacks as described in the installation instructions provided with Voice/Data Adapter Kit, BE01421. Wire the data jacks per the manufacturer's instructions.
2. Place template in desired position on the work surface. Check to be sure there are no support braces or drawers below this area. Drill first 1/8" pilot hole, insert a 1/8" pin (a #8 nail works well) in the hole so the template does not move and drill second pilot hole. Draw a line around the outside of the template and remove.
3. Drill (2) 3/8" (.375) diameter holes in the pilot holes. Cut along the lines with a saber saw.
4. Use the finger holes to slide the template through the hole. Be sure to keep the template horizontal. If there is any interference, use a rasp to remove the interference.

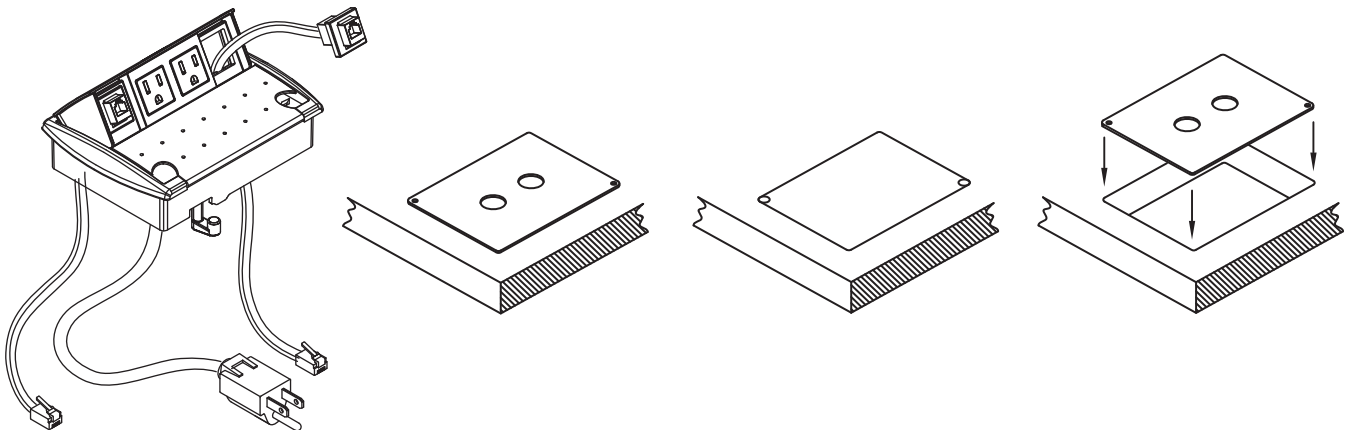

5. Insert Interport into cutout. Use phillips head screwdriver to tighten locking cams snugly to the work surface. **Do not overtighten.**

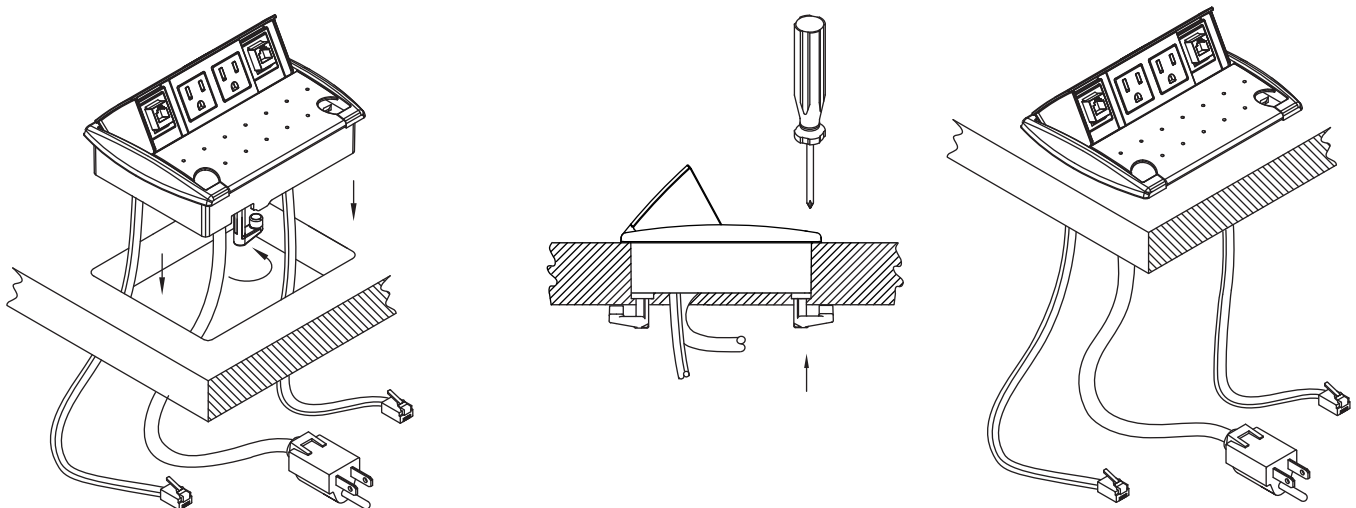

6. Place the cord holder approximately 12" from the Interport using the double faced tape included.

Opening Size

Note: Drawing not to scale

Ganging	"X" Dim.
Single Interport	6.00
Double Interport	12.00
Triple Interport	18.00

